

Manual bidet

Installation manual

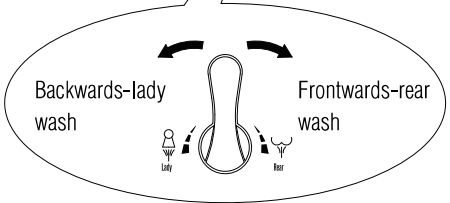
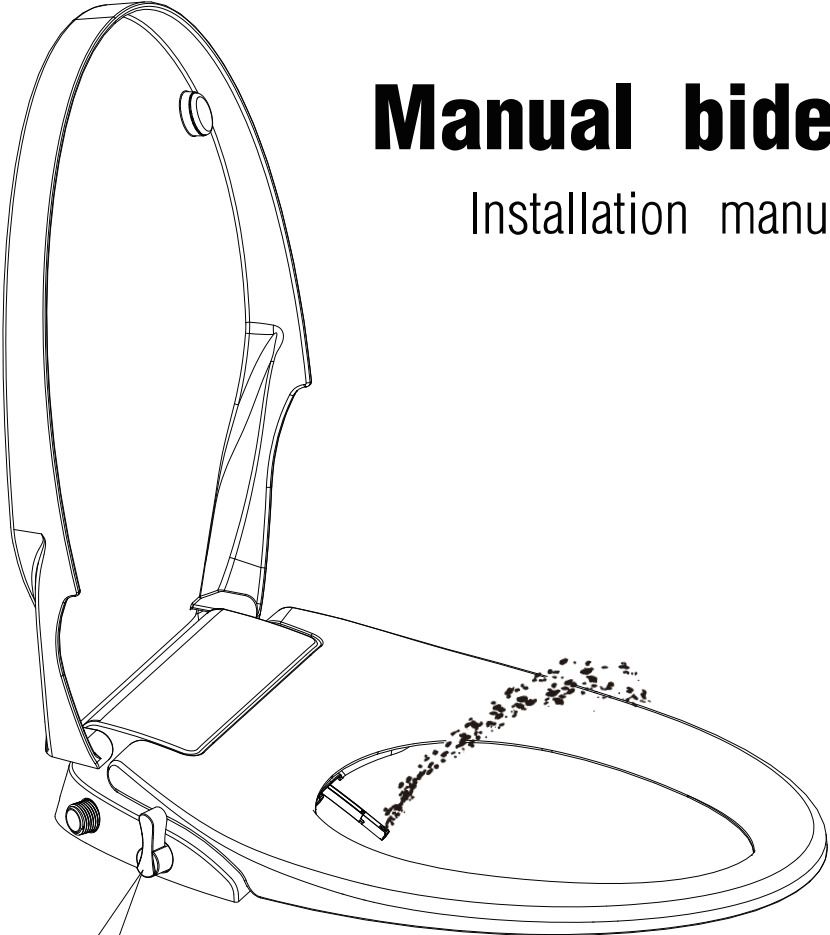

Backwards-lady wash

Frontwards-rear wash

Simple knob, simple operation

SPECIFICATIONS

Classification	Description
Rear wash flow rate	0.35 - 1.8 L/min
Lady wash flow rate	0.35 - 1.8 L/min
Water Supply	Tap water
Water Pressure Range	Static pressure:0.07-0.8 MPa





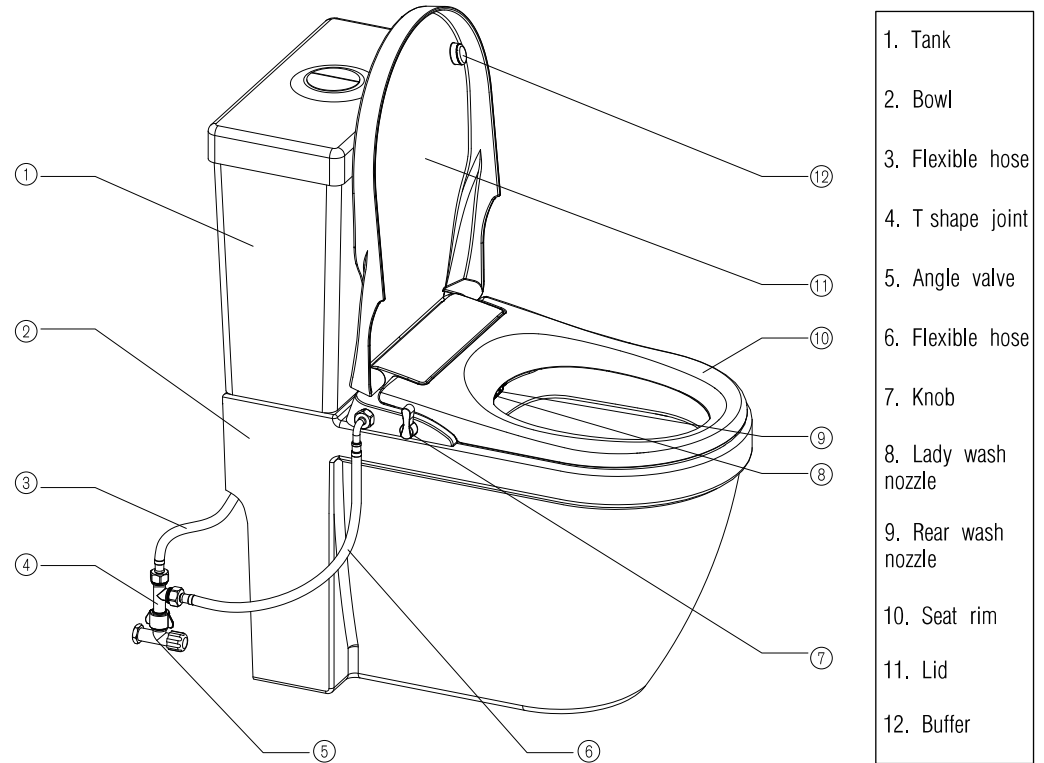

CAUTION

Please do not disassemble, repair or remodel the product.
The water supply must be drinking water rather than rain water, grey water or cycle water.

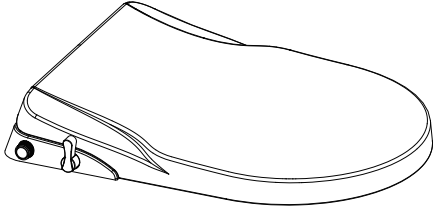
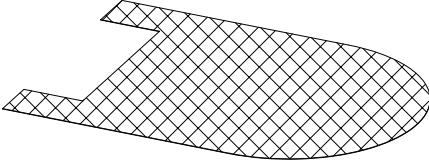
ASSEMBLY DRAWING

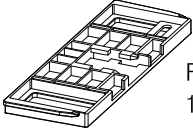

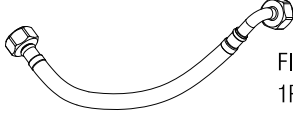
COMPONENTS

Lid 1PCS 		Template 1PCS 	
 Bolts 2PCS	 Plug nuts 2PCS	 Fixing plate 1PCS	
 Washer 2PCS	 Plastic nuts 2PCS		
 Flexible hose 1PCS		 T shape joint 1PCS	 Installation manual 1PCS

INSTALLATION PROCEDURE

Note:

- 1.The plastic nuts are not shown in below procedure. The plastic nuts are used for bottom installation instead of plug nuts in step 2.
- 2.The product can be connected to warm water supply. But the warm water temperature must be within 40℃.
- 3.The supply water pressure limit is from 0.07 to 0.8 MPa. If the water supply pressure is lower than 0.07Mpa (such as the water tank on rooftop),please take out the regulator referring to below figures.

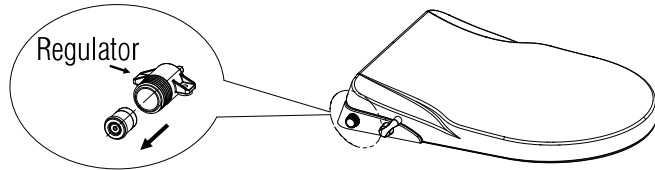

① Disassemble the old seat rim and lid

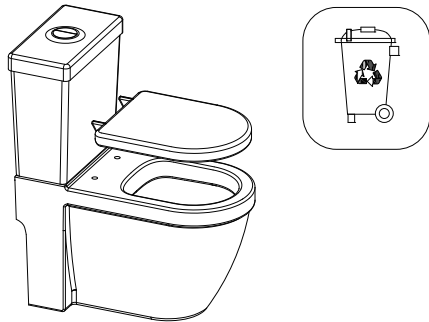

Loose the fastening parts and remove the seat rim and lid. Prepare for assembling a new one.

② Put in the plug nut



Put the plug nuts into the fastening hole on bowl.

③ Place the template

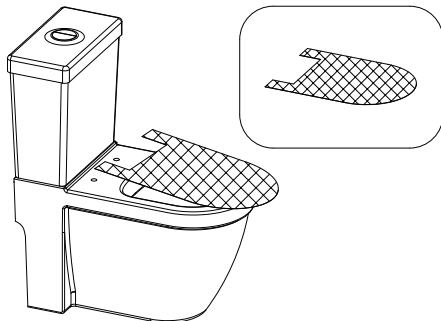

Place the template onto the bowl matching profiles between bidet seat and bowl.

④ Fasten the fixing plate

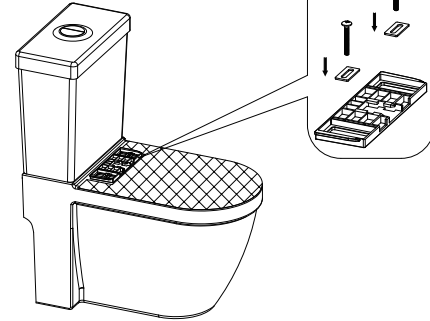

Refer to the figure above,place the fixing plate,washers and bolts onto the bowl in the opening of template.

INSTALLATION PROCEDURE

⑤ Take away the template on the bowl.

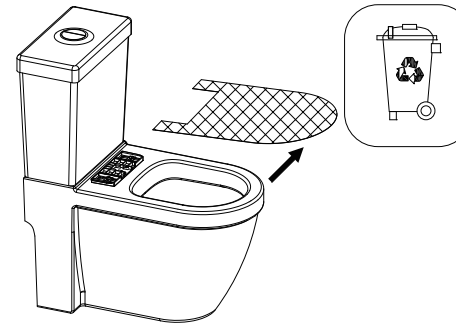

⑥ Assemble the bidet seat

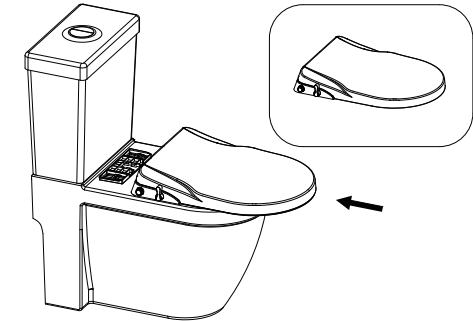

Insert the bidet seat onto the fixing plate and push it to the end. It is fixed while you hear a "click".

(7-1) Connect the flexible hose

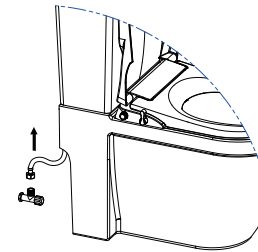

Turn off the inlet valve and loose the flexible hose for tank.

(7-2)

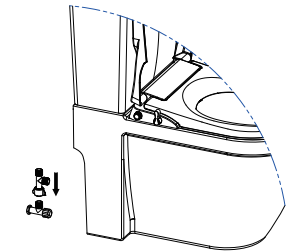

Make sure that flat seal kept in the T shape joint and then connect it to the inlet valve.

(7-3)

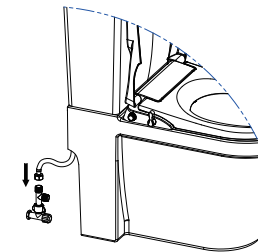

Connect the flexible hose onto the T shape joint

(7-4)

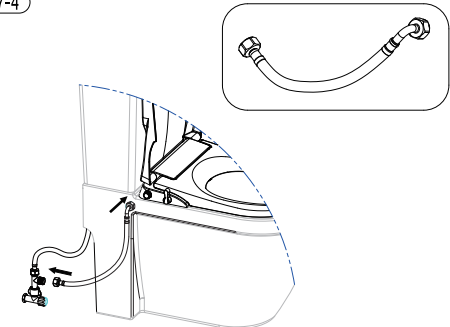

Make sure that flat seal kept in the flexible hose and then connect it to the T shape joint.

MAINTENANCE

① Surface cleaning

Use a smooth sponge/cloth with diluted kitchen detergent to clean the product. The following things are forbidden to use for surface cleaning: hydrogen chloride detergent, paining thinner, benzene, abrasive paper, polishing agent, fragrance and insecticide, etc.

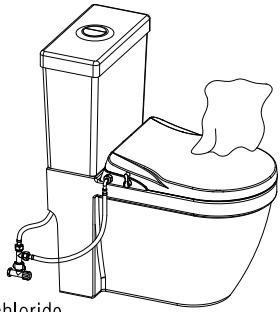

② Remove the bidet seat

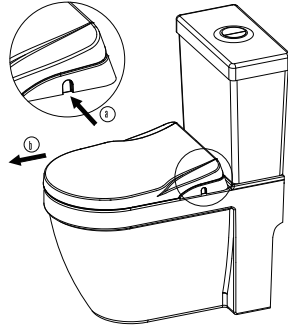

Keep the lid closed. Push the button on side and pull the bidet seat along the arrow shown in figure.

③ Nozzle cleaning

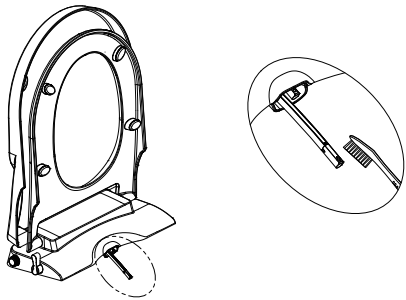

Pull out the nozzle softly and use cloth/sponge or toothbrush with kitchen detergent to clean it.

④ Nozzle replacement

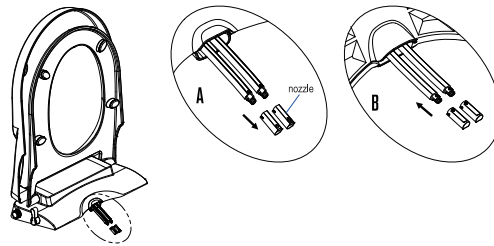

1. Pull out the nozzle softly and hold the tube. Remove the nozzle along the arrow direction as figure A.
2. Hold the tube and insert the new nozzle along the arrow direction as figure B

⑤ Knob replacement

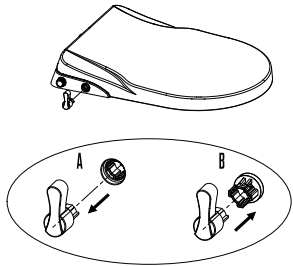

1. Pull out the old knob along the arrow direction as figure A.
2. Insert the new knob along the arrow direction as figure B.

⑥ Regulator replacement

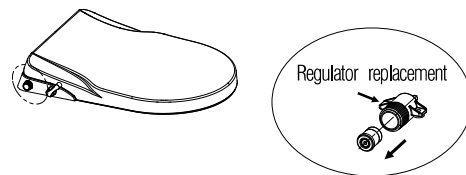

1. Rotate the knob to be rear wash/Lady wash, clip out the regulator from the inlet tube with tool
2. Insert the new regulator into the inlet tube. Rotate the knob to non-working position.
Note: The regulator must be in right direction which the water can get through.

TROUBLE SHOOTING

Status	Cause	Solution
The water spray too low	The valve opening is not enough	Turn the knob to be max position.
	The water pressure is lower than 0.07Mpa	Refer to the step 6 in maintenance part, take out the regulator. Please contact the service staff if it still doesn't work
No water come out	The water shut-off valve is turned off	Turn on the water shut-off valve.
	The filter screen in flexible hose is stuck	Clean the filter screen in flexible hose
	The Nozzle is stuck	Take off the nozzle and clean it.
	The water supply pressure is too low	Increase the external water pressure
Water leaks from the bidet seat base part	The water supply pressure is too high	The maximum pressure that product can afford is 0.8Mpa
If any failure still occurs after above trouble-shooting. Please contact the service		